

# Horizontal distribution busbar HX<sup>3</sup> 80/125 A plug-in

Cat. N° (s): 4 052 23/40/41/42/43/44/45/46

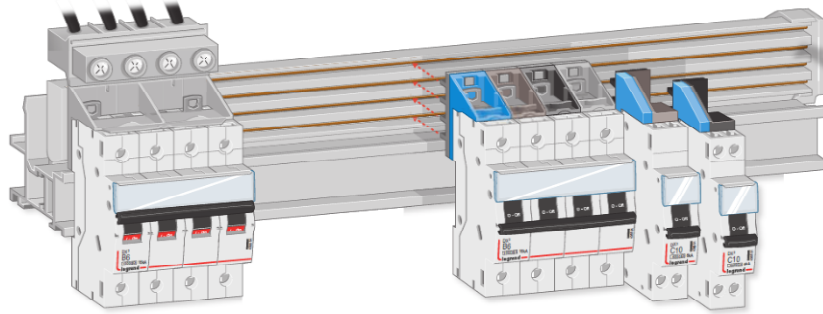

CONTENTS	Pages
1. Description.....	1
2. Range.....	1
3. Overall dimensions .....	1
4. Preparation - Connection .....	3
5. General Characteristics .....	8
6. Compliance and approvals.....	9

## 1. DESCRIPTION

### 1. DESCRIPTION - USE

Plug-in horizontal distribution system: used for 3-phase distribution without wiring of modular devices up to 125 A on a single row. Automatic connection and disconnection of equipment totally safely, even when the distribution busbar is powered-up, thanks to the IP XXB insulation and the integral connection modules in the devices. Total freedom to install and combine devices: 1P+N, 2P, 3P, 4P, add-on modules, auxiliaries, control devices, etc. Selection of the phase to be connected by selecting the connection module.

For mounting in XL<sup>3</sup> 400/800/4000 enclosures with 2-position aluminium rail (Cat.nos 0 202 06, 0 206 01/51) and in XL<sup>3</sup> 160 enclosures with the mounting accessory (Cat. no 4 052 24). It can be used in panel h = 150mm.

## 2. RANGE

### Automatic distribution blocks

. Fixed directly onto DIN rails Cat nos 0 202 06, 0 206 01/51. Delivered with a supply module and a phase security cover of the distribution busbar  
Cat. no 4 052 40: 24 modules  
Cat. no 4 052 41: 36 modules

### Connection modules:

. Used for automatic connection and disconnection of modular devices on the horizontal distribution busbar.  
Cat. n° 4 052 43: set of 10 connection modules L1  
Cat. n° 4 052 44: set of 10 connection modules L2  
Cat. n° 4 052 45: set of 10 connection modules L3  
Cat. n° 4 052 46: set of 10 connection modules N for devices 1 module per pole.  
Cat. n° 4 052 23: set of 3 connection modules L1N, L2N, L3N for devices 1P+N in 1 module screws or automatic terminals.

### Accessories for mounting in XL<sup>3</sup> 160 enclosure

Cat. n° 4 052 24: used for mounting the 80/125 A horizontal busbar 24 modules (cat. n° 4 052 40) in XL<sup>3</sup> 160 enclosure.

### Rated Voltages and Frequency:

. 230 V ~ / 400 V~ - 50 / 60 Hz with standard tolerances.

### Rated Currents:

. Max.125 A (with the power supply module).  
. Max.80 A (without the power supply module).

## 3. OVERALL DIMENSIONS

. Distribution busbar:

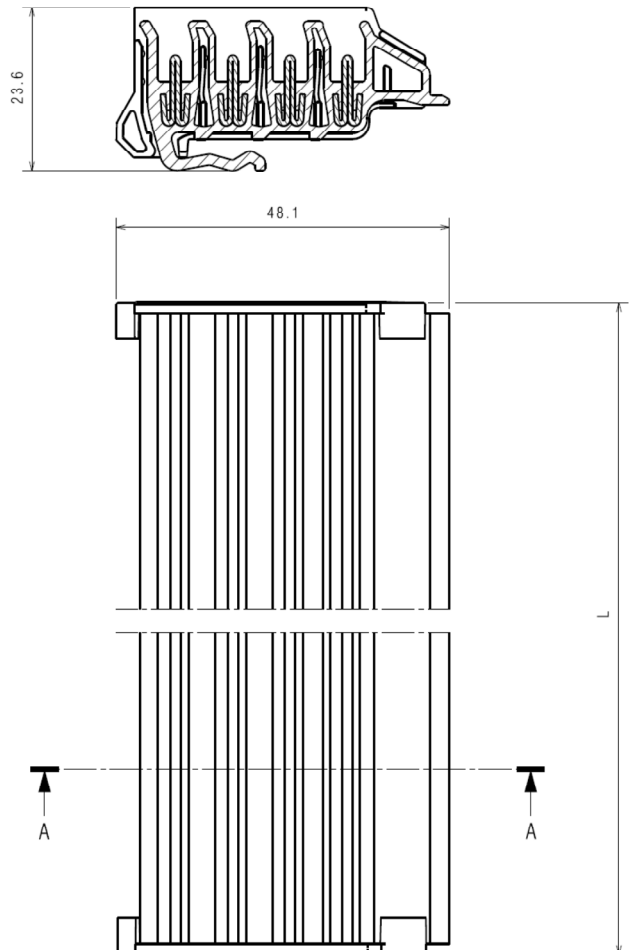

Modules	L (mm)
24	432
36	652

# Horizontal distribution busbar HX<sup>3</sup> 80/125 A plug-in

Cat. N° (s): 4 052 23/40/41/42/43/44/45/46

## 3. OVERALL DIMENSIONS (continued)

. Power supply module, cat n° 4 052 42:

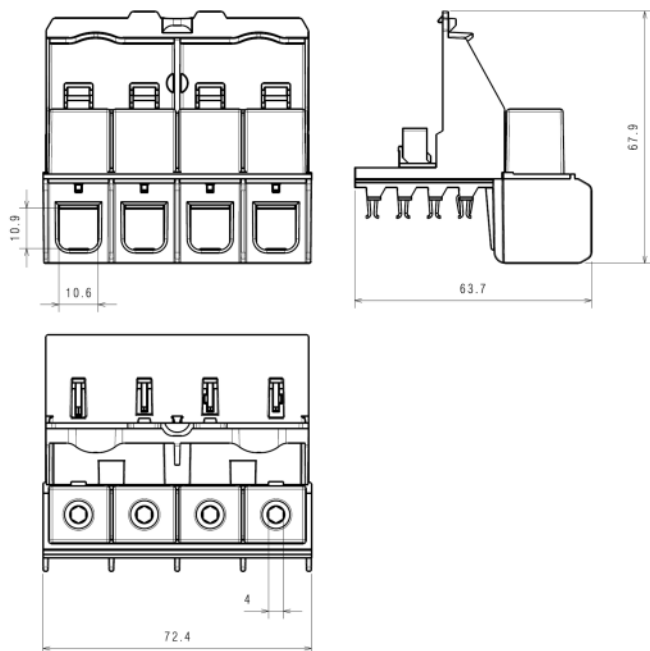

. Power supply security module (delivered with power supply module):

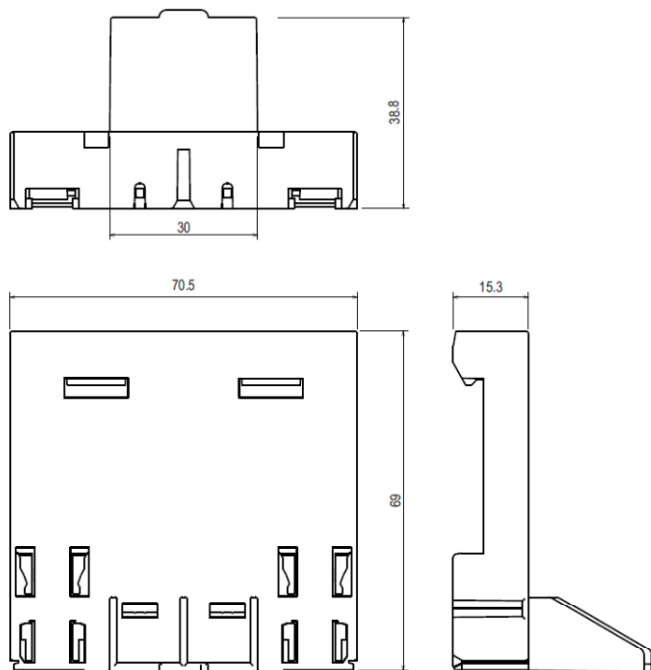

## 3. OVERALL DIMENSIONS (continued)

. Connection module 1P, cat n°(s) 4 052 43/44/45/46:

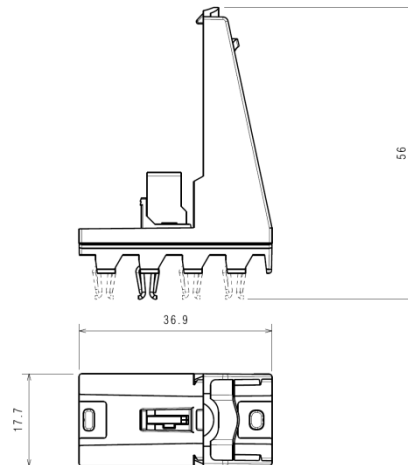

. Connection module 1P+N (Cat. no 4 052 23):

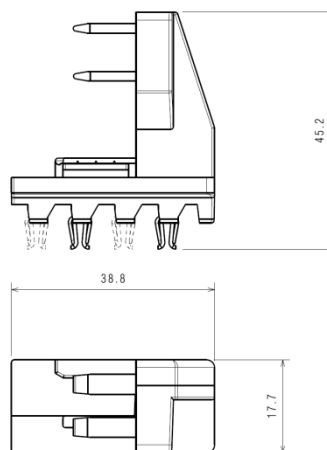

. Lateral view of the cabled system:

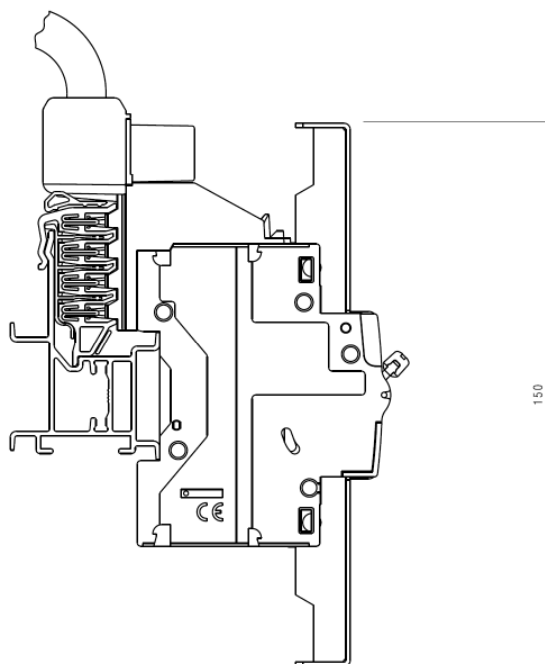

# Horizontal distribution busbar HX<sup>3</sup> 80/125 A plug-in

Cat. N° (s): 4 052 23/40/41/42/43/44/45/46

## 4. PREPARATION - CONNECTION

### Fixing:

. On dedicated rail cat. no 4 052 26.

### List of modular compatible devices:

DX <sup>3</sup> Modular compatible device:	Connection modules
MCBs 1P+N in 1 module, automatic or screws terminals	4 052 23 (L1N, L2N, L3N) neutral on the left
RCBOs 1P+N feeder protection	
RCDs 1P+N feeder protection	
RCDs 2P feeder protection	4 052 43: L1 4 052 44: L2 4 052 45: L3 4 052 46: N
RCDs 4P feeder protection	
RCBOs 2P feeder protection	
RCBOs 4P feeder protection	
MCBs 1P, 2P, 3P, 4P 1 module/pole (*)	
MCBs 2p and 4P associated to RCD add-on modules	
IS	

(\*)Except products dedicated to four pole Prong busbars HX<sup>3</sup>

### System power supply:

. Direct power supply via the power supply module. In this configuration the operating current can be max 125A.

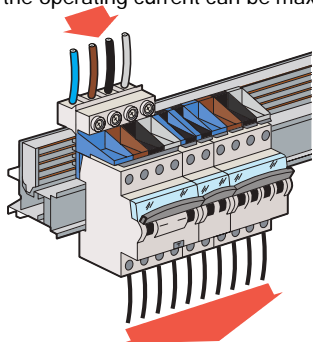

. Indirect power supply via head of row device:

The distribution busbar is protected by the head of group device. In this configuration the operating current is limited by the rated current of the head device (max. 80A).

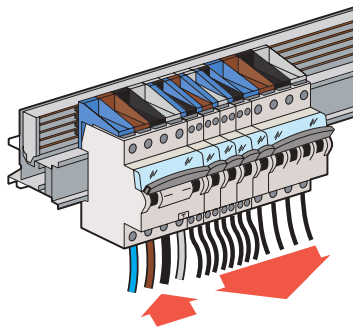

## 4. PREPARATION - CONNECTION (continued)

### Assembly of the various elements of the system:

. Horizontal distribution busbar:  
XL<sup>3</sup> 400, XL<sup>3</sup> 800, XL<sup>3</sup> 4000 enclosures

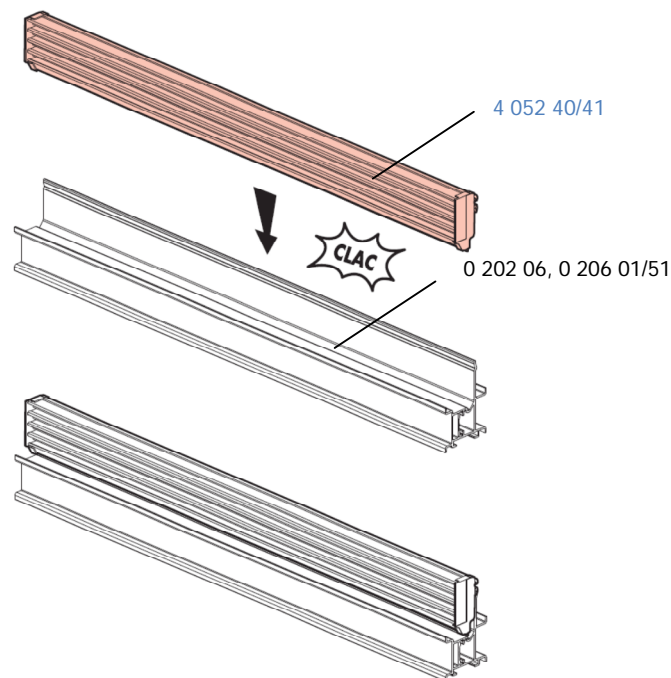

# Horizontal distribution busbar HX<sup>3</sup> 80/125 A plug-in

Cat. N° (s): 4 052 23/40/41/42/43/44/45/46

## 4. PREPARATION - CONNECTION (continued)

### Assembly of the various elements of the system (continued):

- . Horizontal distribution busbar (continued):
- XL<sup>3</sup> 160 enclosure

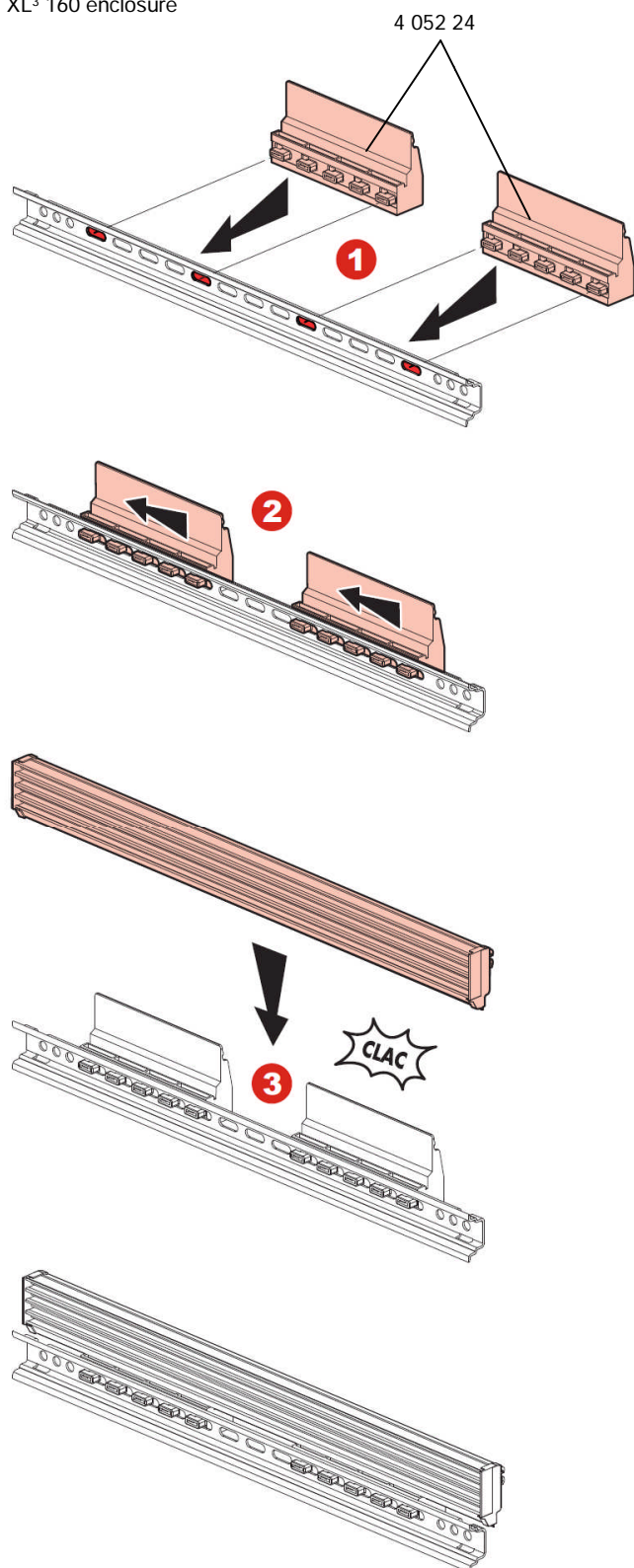

## 4. PREPARATION - CONNECTION (continued)

### Assembly of the various elements of the system (continued):

- . Supply module associated to an MCB:

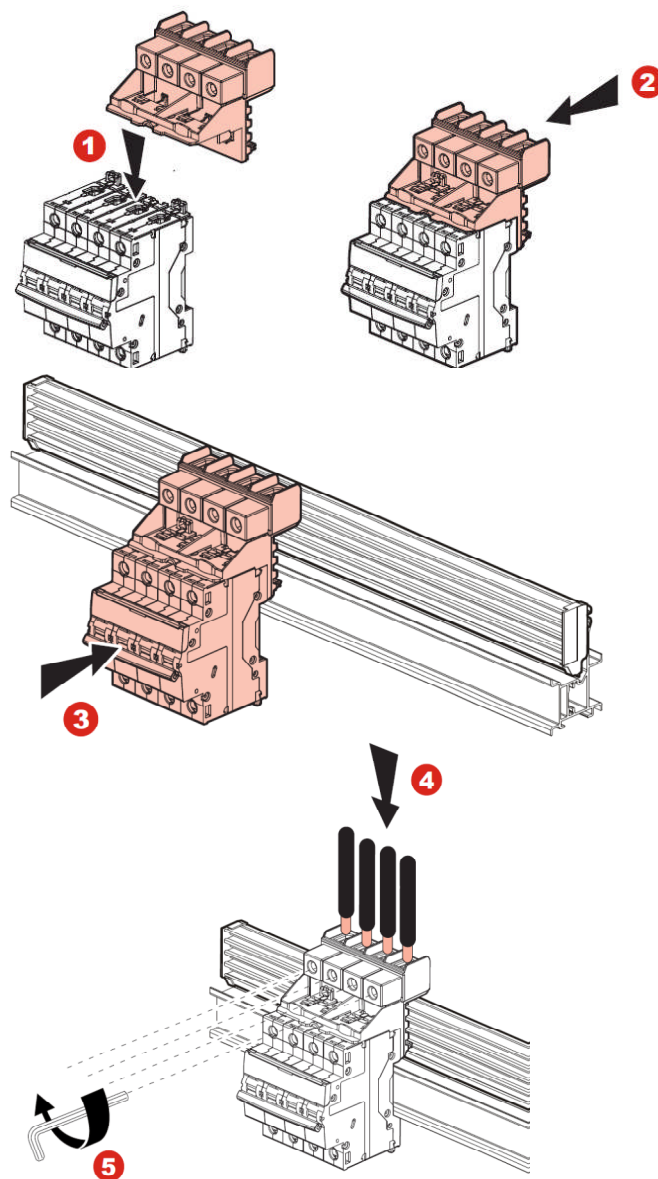

Supply module - Terminal capacity:

	Copper cables	
	Without ferrule	Without ferrule
Rigid cable	6 mm <sup>2</sup> à 50 mm <sup>2</sup>	-
Flexible cable	6 mm <sup>2</sup> à 35 mm <sup>2</sup>	6 mm <sup>2</sup> à 35 mm <sup>2</sup>

Tightening torque:

- . Recommended: 4Nm.
- . Min: 3 Nm. Max: 5 Nm.

Tools required:

- . For the terminals: Allen wrench 4 mm.



# Horizontal distribution busbar HX<sup>3</sup> 80/125 A plug-in

Cat. N° (s): 4 052 23/40/41/42/43/44/45/46

## 4. PREPARATION - CONNECTION (continued)

### Assembly of the various elements of the system (continued):

. Supply module (cat n° 4 052 42) associated to the power supply security module: used to supply directly the busbar.

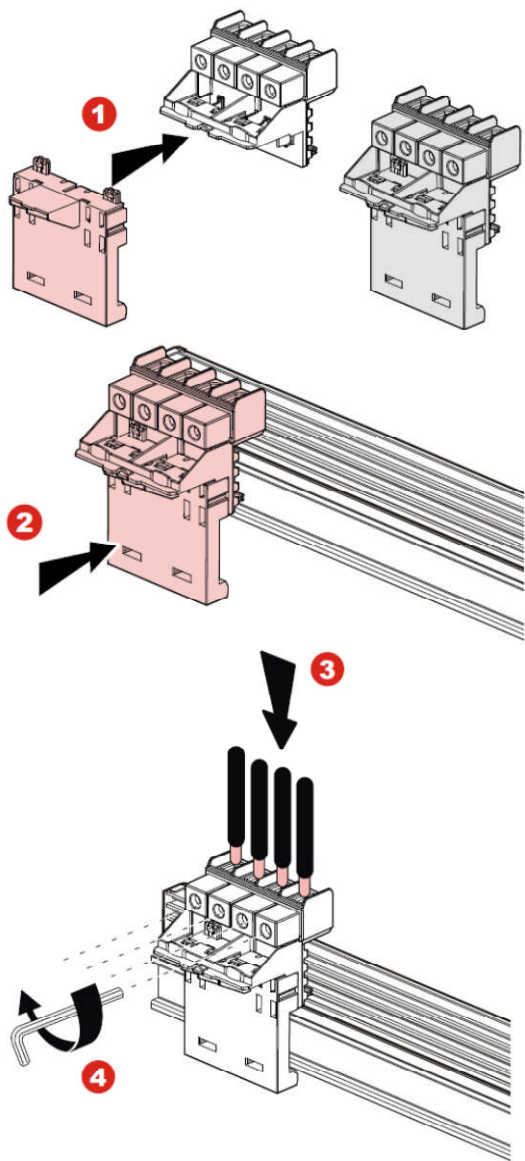

Supply module - Terminal capacity:

	Copper cables	
	Without ferrule	With ferrule
Rigid cable	6 mm <sup>2</sup> a 50 mm <sup>2</sup>	-
Flexible cable	6 mm <sup>2</sup> a 35 mm <sup>2</sup>	6 mm <sup>2</sup> a 35 mm <sup>2</sup>

Tightening torque:

. Recommended: 4Nm.  
. Min: 3 Nm. Max: 5 Nm.

Tools required:

. For the terminals: Allen wrench 4 mm.

## 4. PREPARATION - CONNECTION (continued)

### Assembly of the various elements of the system (continued):

. Connection modules 1P (cat. n°(s) 4 052 43/44/45/46):

No tools required to assembly the connection module to the device.

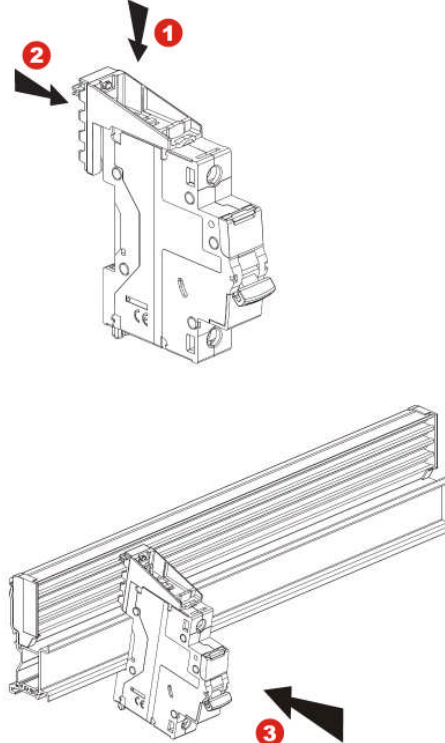

. Connection module 1P+N (cat. n° 4 052 23):

No tools required to assembly the connection module to the MCB 1P+N in 1 module with automatic terminals

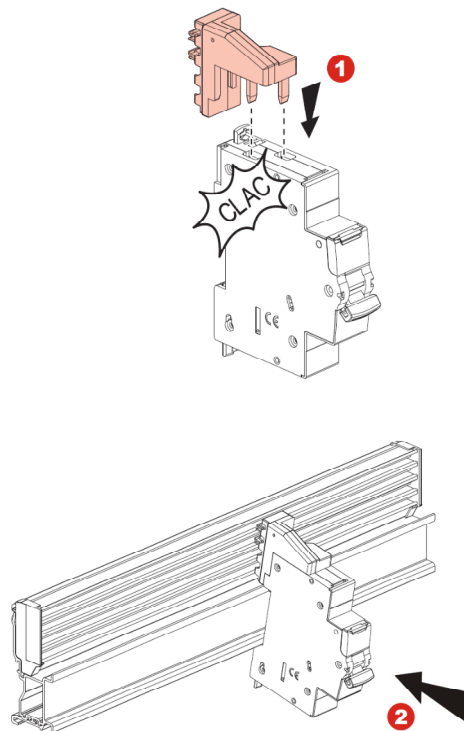

# Horizontal distribution busbar HX<sup>3</sup> 80/125 A plug-in

Cat. N° (s): 4 052 23/40/41/42/43/44/45/46

## 4. PREPARATION - CONNECTION *(continued)*

### Assembly of the various elements of the system *(continued)*:

. Connection module 1P+N (cat. n° 4 052 23: neutral on the left):

To assembly the connection module to the device 1P+N in 1 module is necessary a screwdriver Pozidriv n° 2.

Recommended tightening torque: 1.6 to 2 Nm.

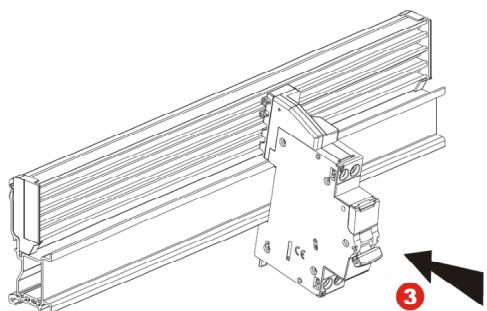
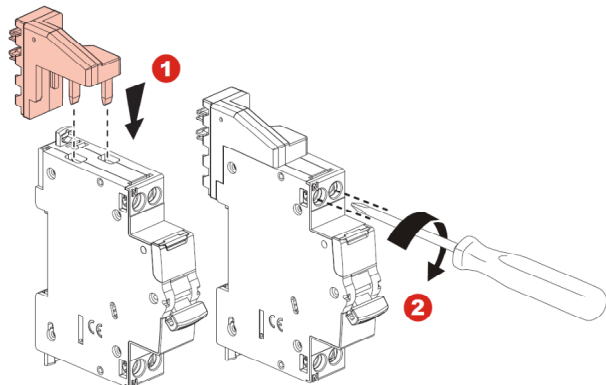

## 4. PREPARATION - CONNECTION *(continued)*

### Assembly of the various elements of the system in case of use of a MCCB:

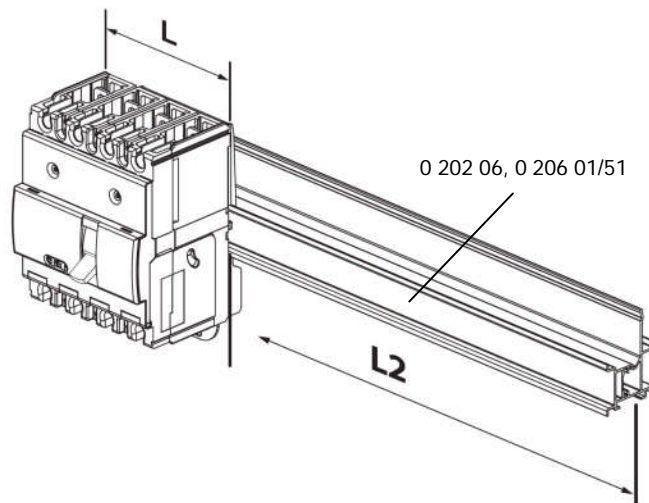

DPX <sup>3</sup>	L (mm)	
	3P	4P
160	82	108
250	105	140

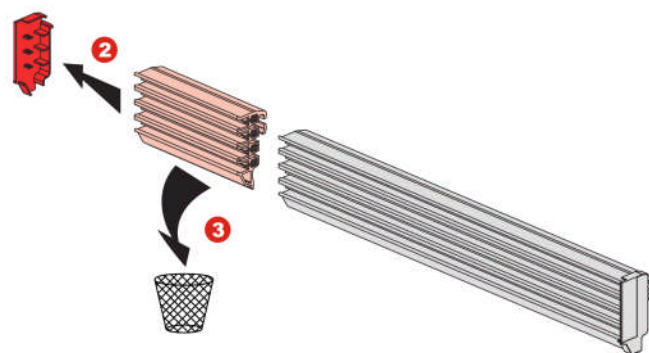
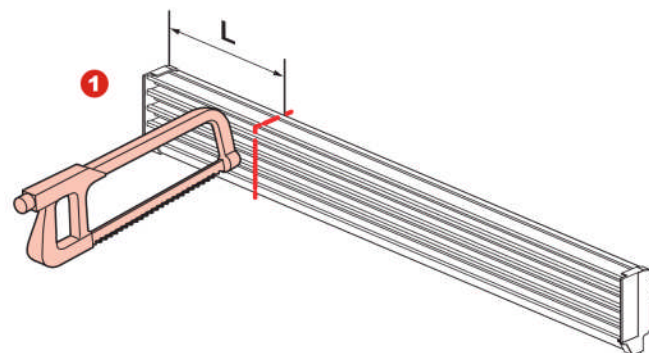

4. PREPARATION - CONNECTION (continued)

Assembly of the various elements of the system in case of use of a MCCB:

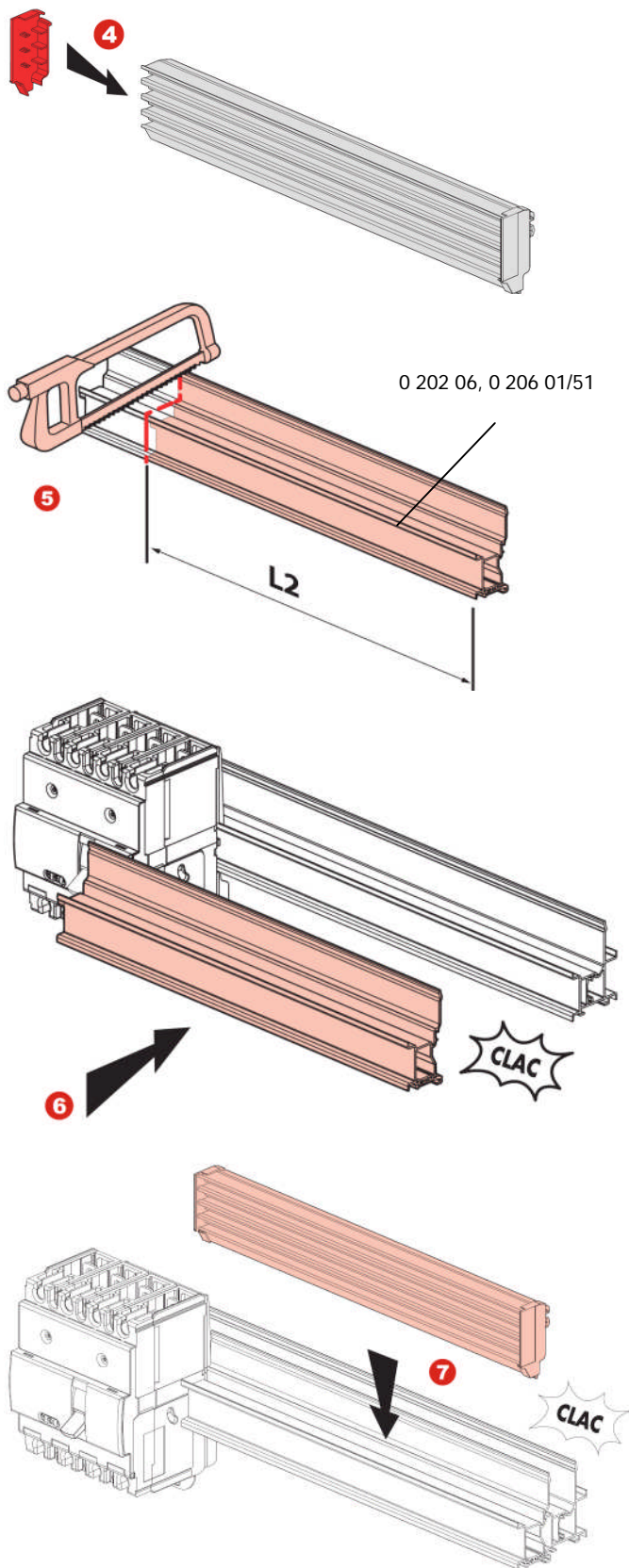

4. PREPARATION - CONNECTION (continued)

Supply of a device that can't be equipped with the connection modules:

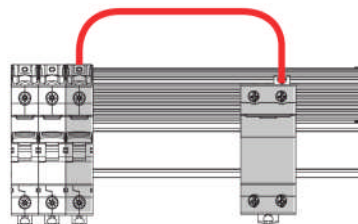

- . This operation is possible with the connection modules 1P.
- . Fix the device to be powered on the DIN rail Cat nos 0 202 06, 0 206 01/51.
- . Break the pre-fracture on the connection module and connect the supply cables between the switch and the device to be powered.

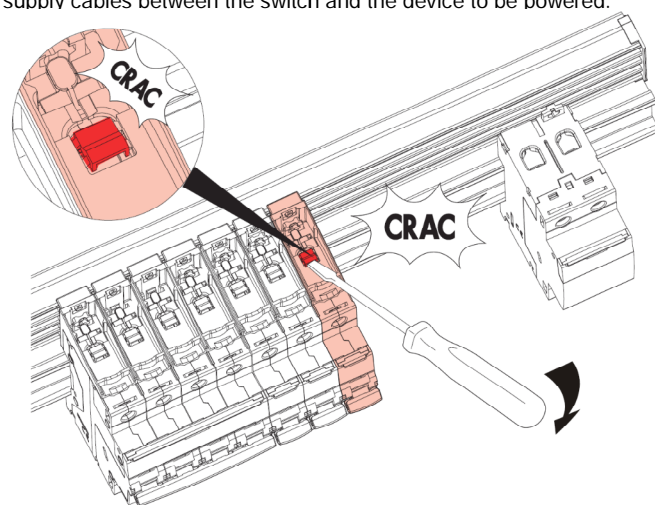

**WARNING:** In this configuration the maximum current derivable from the devices is 80A.

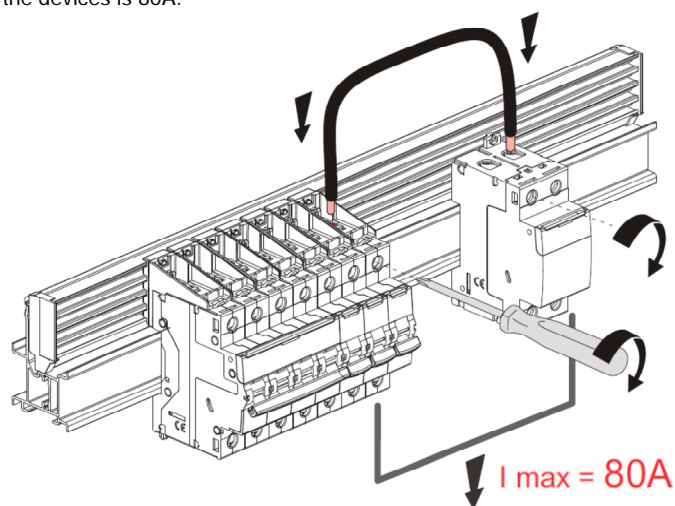

# Horizontal distribution busbar HX<sup>3</sup> 80/125 A plug-in

Cat. N° (s): 4 052 23/40/41/42/43/44/45/46

## 5 GENERAL CHARACTERISTICS

### Rated peak withstand current (I<sub>pk</sub>):

- . 25kA at 400V

### Rated short-time current (I<sub>cw</sub>):

- . 6 kA per 0,1 s
- . 2,5 kA per 0,3 s
- . 2 kA per 1 s

### Rated impulse withstand voltage:

- . U<sub>imp</sub> = 4kV according to IEC 61439-2, 61439-3

### Maximum power loss at 125 A (W):

- . 17,4 W for the distribution busbar 24 modules (cat. n° 4 052 40).
- . 26,4 W for the distribution busbar 36 modules (cat. n° 4 052 41)

### Maximum power loss at 80 A (W):

- . 7,1 W for the distribution busbar 24 modules (cat. n° 4 052 40).
- . 10,8 W for the distribution busbar 36 modules (cat. n° 4 052 41)

### Rated insulation voltage:

- . U<sub>i</sub> = 500 V according to IEC 60493-1

### Pollution degree:

- . 2.

### Plastic materials:

- . All insulating parts (distribution busbar, supply module, connection modules 1P+N, 1P) comply with the glow-wire test (IEC/EN 60695-2-11).

Horizontal distribution busbar is made of self-extinguishing materials in accordance with the standard IEC/EN 60695-11-10.

### Higher calorific value (HCV):

- . Distribution busbar 24 modules: 3,112 MJ
- . Distribution busbar 36 modules: 4,738 MJ
- . Connection module (1P and 1P+N): 0,159 MJ
- . Power supply module: 0,636 MJ
- . Power supply security module: 0,154 MJ

### Protection index:

- . Protection index against solid and liquid bodies: IP 20 (IEC 529, EN 60529 et NF C 20-010).

### Resistance to sinusoidal vibrations:

- . According to IEC 60068-2-35.
- . Axis: x, y, z.
- . Frequency range: 5÷100 Hz; duration 90 minutes
- . Displacement (5÷13,2 Hz): 1mm.
- . Acceleration (13,2÷100 Hz): 0,7g (g=9,81 m/s<sup>2</sup>)

### Average weight of each element of the system:

- . Distribution busbar 24 modules: 0,501 kg
- . Distribution busbar 36 modules: 0,675 kg
- . Power supply module: 0,136 kg
- . Connection module 1P: 0,010 kg
- . Connection module 1P+N: 0,019 kg.
- . Power supply security module: 0,033kg

## 5 GENERAL CHARACTERISTICS (continued)

### Volume when packed:

	Volume (dm <sup>3</sup> )
Distribution busbar 24 modules (pack per 5)	3,3
Distribution busbar 24 modules (pack per 5)	4,8
Supply module + Power supply security module (pack. per 1)	0,75
Connection module 1P (pack. per 10)	0,75
Connection module 1P+N, in bag of 3 pieces (pack. per 5 bags)	0,995
Accessory for mounting in XL <sup>3</sup> 160 enclosure	3,675

### Ambient operating temperature:

- . Min. = -25°C. Max. = +70°C

### Ambient storage temperature:

- . Min. = -40°C. Max. = +70°C



## 6. COMPLIANCE AND APPROVALS

### Compliance to standards:

- . Reference standard: IEC 61439

### Environment respect – Compliance with CEE directives:

- . Compliance with Directive 2002/95/EC of 27.1.2003 called "RoHS" provides the banishment of hazardous substances such as lead, mercury, cadmium, hexavalent chromium, brominated flame retardants polybrominated biphenyls (PBB) and polybrominated diphenylethers (PBDE) from 1 July 2006
- . Compliance with Directives 91/338/CEE of 18/06/91 and decree 94-647 of 27/07/04.
- . Compliance with Directives 73/23/CEE and 93/68/CEE (DBT).
- . Compliance with Directives 83/336/CEE, 92/31/CEE and 93/68/CEE (CEM)

### Plastic materials:

- . Halogen-free plastic materials.
- . Marking of parts according to ISO 11469 and ISO 1043.

### Packaging:

- . Design and manufacture of packaging in accordance with decree 98-638 of 20.07.1998 and Directive 94/62/EC.